

# A Framework for Processing Large Graphs in Shared Memory

---

Julian Shun

Based on joint work with Guy Blelloch and Laxman Dhulipala

# What are graphs?

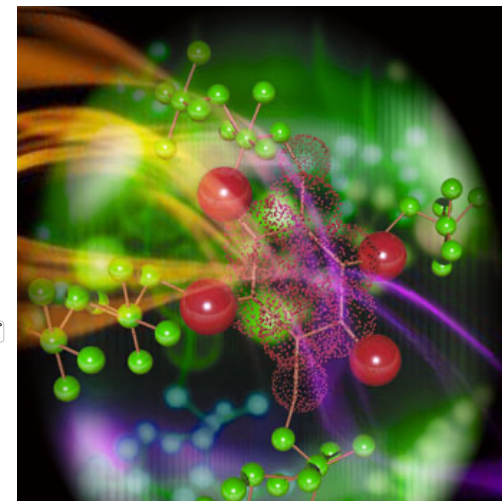
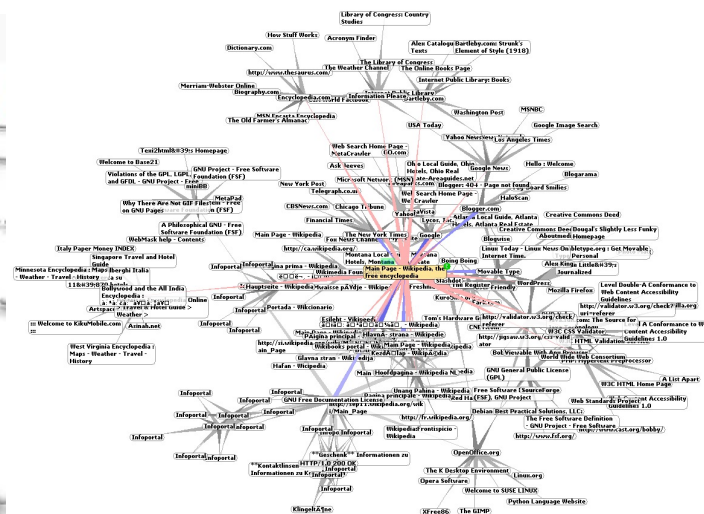

*Graph Data is Everywhere!*

- Can contain up to billions of vertices and edges
- Need simple, efficient, and scalable ways to analyze them

# Efficient Graph Processing

- Use parallelism

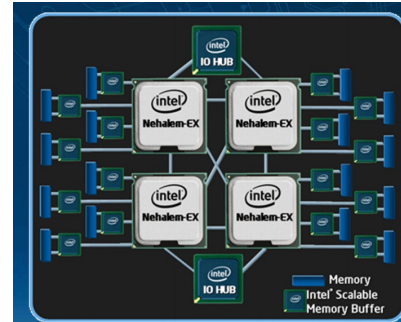

- Design efficient algorithms

Breadth-first search  
 Betweenness centrality  
 Connected components  
 ...

Single-source shortest paths  
 Eccentricity estimation  
 (Personalized) PageRank  
 ...

- Write/optimize code for each application
- Build a general framework

# Ligra Graph Processing Framework

EdgeMap

VertexMap

Breadth-first search  
Betweenness centrality  
Connected components  
Triangle counting  
K-core decomposition  
Maximal independent set  
Set cover

Single-source shortest paths  
Eccentricity estimation  
(Personalized) PageRank  
Local graph clustering  
Biconnected components  
Collaborative filtering  
...

*Simplicity, Performance, Scalability*

# Graph Processing Systems

- Existing: Pregel/Giraph/GPS, GraphLab, Pegasus, Knowledge Discovery Toolbox, GraphChi, etc.
- Our system: **Ligra** - Lightweight graph processing system for shared memory

*Takes advantage of “frontier-based”  
nature of many algorithms  
(active set is dynamic and often small)*

# Breadth-first Search (BFS)

- Compute a BFS tree rooted at source  $r$  containing all vertices reachable from  $r$

Applications
Betweenness centrality
Eccentricity estimation
Maximum flow
Web crawlers
Network broadcasting
Cycle detection
...

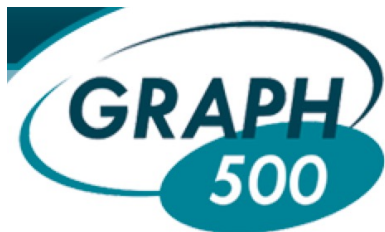
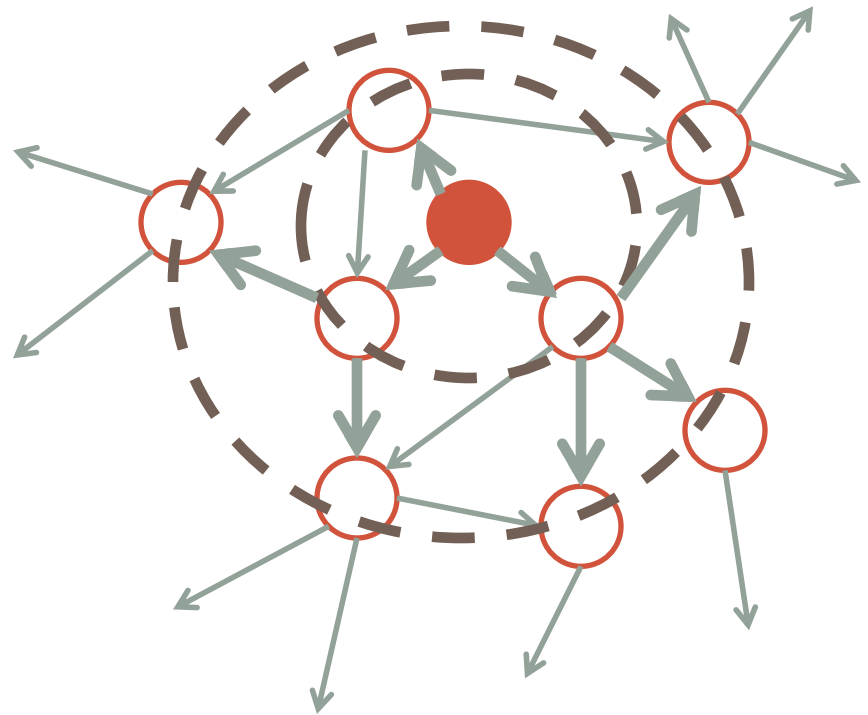

- Can process each frontier in parallel
- Race conditions, load balancing

# Steps for Graph Traversal

Many graph traversal algorithms do this!

- Operate on a subset of vertices
- Map computation over subset of edges **in parallel**
- Return new subset of vertices
- Map computation over subset of vertices **in parallel**

VertexSubset

EdgeMap

VertexMap

*We built the **Ligra** abstraction for these kinds of computations*

*Think with flat data-parallel operators*

*Abstraction enables optimizations  
(hybrid traversal and graph compression)*

# Breadth-first Search in Ligra

```
parents = {-1, ..., -1}; // -1 indicates "unexplored"
```

```
procedure UPDATE(s, d):
```

```
    return compare_and_swap(parents[d], -1, s);
```

```
procedure COND(v):
```

```
    return parents[v] == -1; // checks if "unexplored"
```

```
procedure BFS(G, r):
```

```
    parents[r] = r;
```

```
    frontier = {r}; // VertexSubset
```

```
    while (size(frontier) > 0):
```

```
        frontier = EDGEMAP(G, frontier, UPDATE, COND);
```

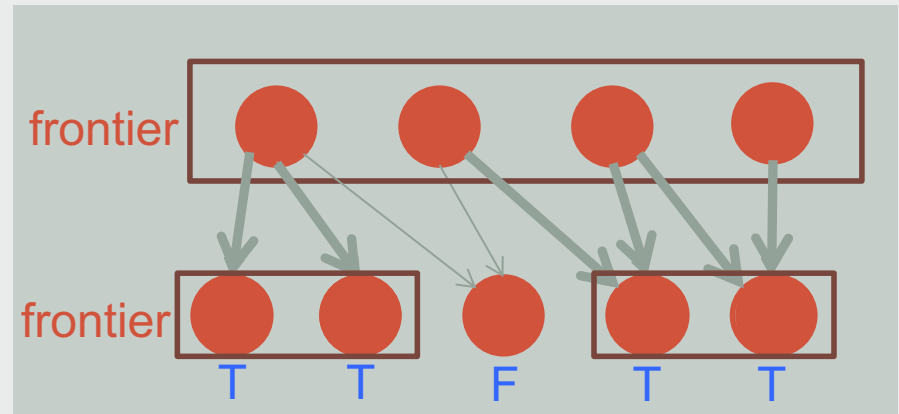



# Actual BFS code in Ligra

```

#include "ligra.h"

struct BFS_F {
    intT* Parents;
    BFS_F(intT* _Parents) : Parents(_Parents) {}
    inline bool update (intT s, intT d) { //Update
        if(Parents[d] == -1) { Parents[d] = s; return 1; }
        else return 0;
    }
    inline bool updateAtomic (intT s, intT d){ //atomic version of Update
        return (CAS(&Parents[d],(intT)-1,s));
    }
    //cond function checks if vertex has been visited yet
    inline bool cond (intT d) { return (Parents[d] == -1); }
};

template <class vertex>
void Compute(graph<vertex> GA, intT start) {
    intT n = GA.n;
    //creates Parents array, initialized to all -1, except for start
    intT* Parents = newA(intT,GA.n);
    parallel_for(intT i=0;i<GA.n;i++) Parents[i] = -1;
    Parents[start] = start;

    vertexSubset Frontier(n,start); //creates initial frontier

    while(!Frontier.isEmpty()){ //loop until frontier is empty
        vertexSubset output = edgeMap(GA, Frontier, BFS_F(Parents));
        Frontier.del();
        Frontier = output; //set new frontier
    }
    Frontier.del();
    free(Parents);
}

```

# Sparse or Dense EdgeMap?

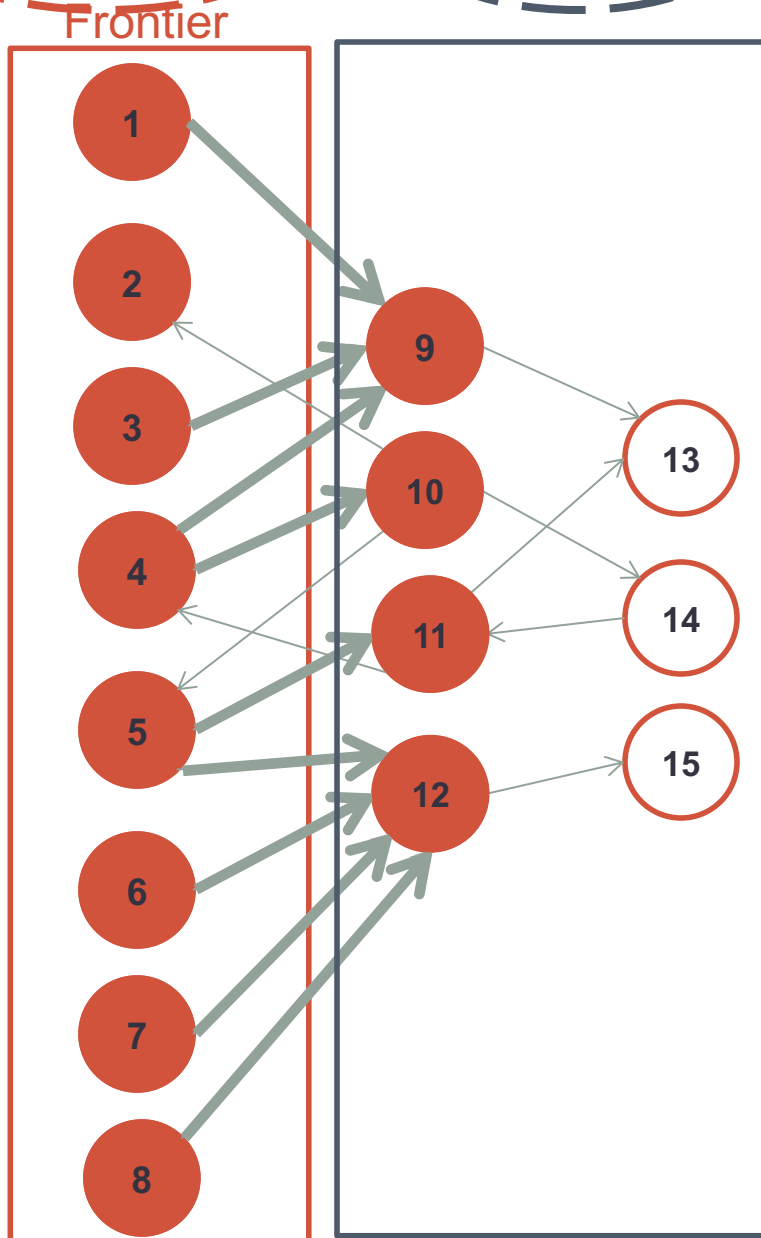

- Dense method better when frontier is large and many vertices have been visited
- Sparse (traditional) method better for small frontiers
- Switch between the two methods based on frontier size [Beamer et al. SC '12]

*Limited to BFS?*

# EdgeMap

```
procedure EDGEMAP(G, frontier, Update, Cond):  
  if (size(frontier) + sum of out-degrees > threshold) then:  
    return EDGEMAP_DENSE(G, frontier, Update, Cond);  
  else:  
    return EDGEMAP_SPARSE(G, frontier, Update, Cond);
```



Loop through outgoing edges of frontier vertices in parallel



Loop through incoming edges of “unexplored” vertices (in parallel), breaking early if possible

- **More general than just BFS!**
- Generalized to many other problems
  - For example, betweenness centrality, connected components, sparse PageRank, shortest paths, eccentricity estimation, graph clustering, k-core decomposition, set cover, etc.
- Users need not worry about this

# Frontier-based approach enables hybrid traversal

Twitter graph (41M vertices, 1.5B edges)

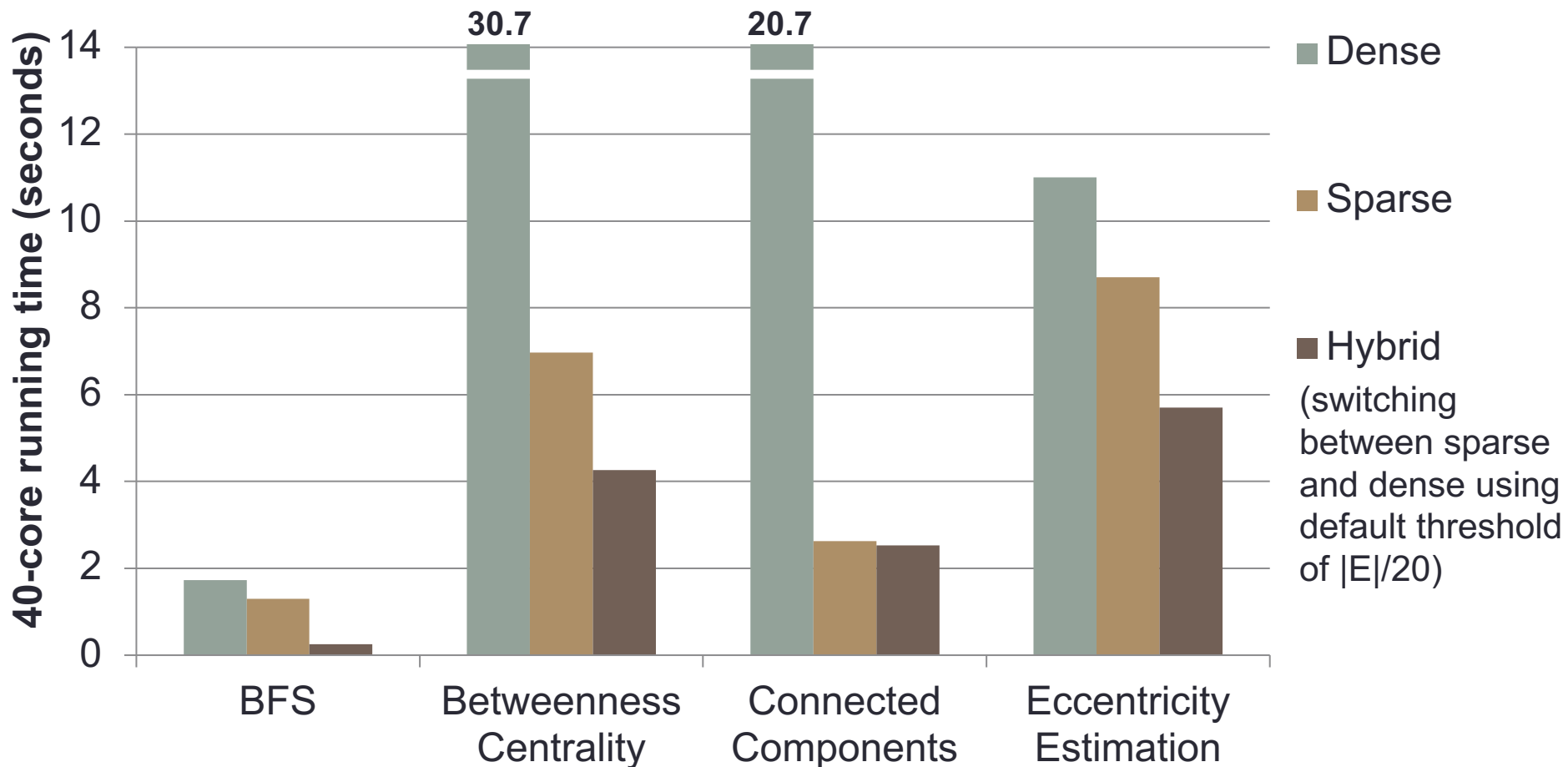

# PageRank

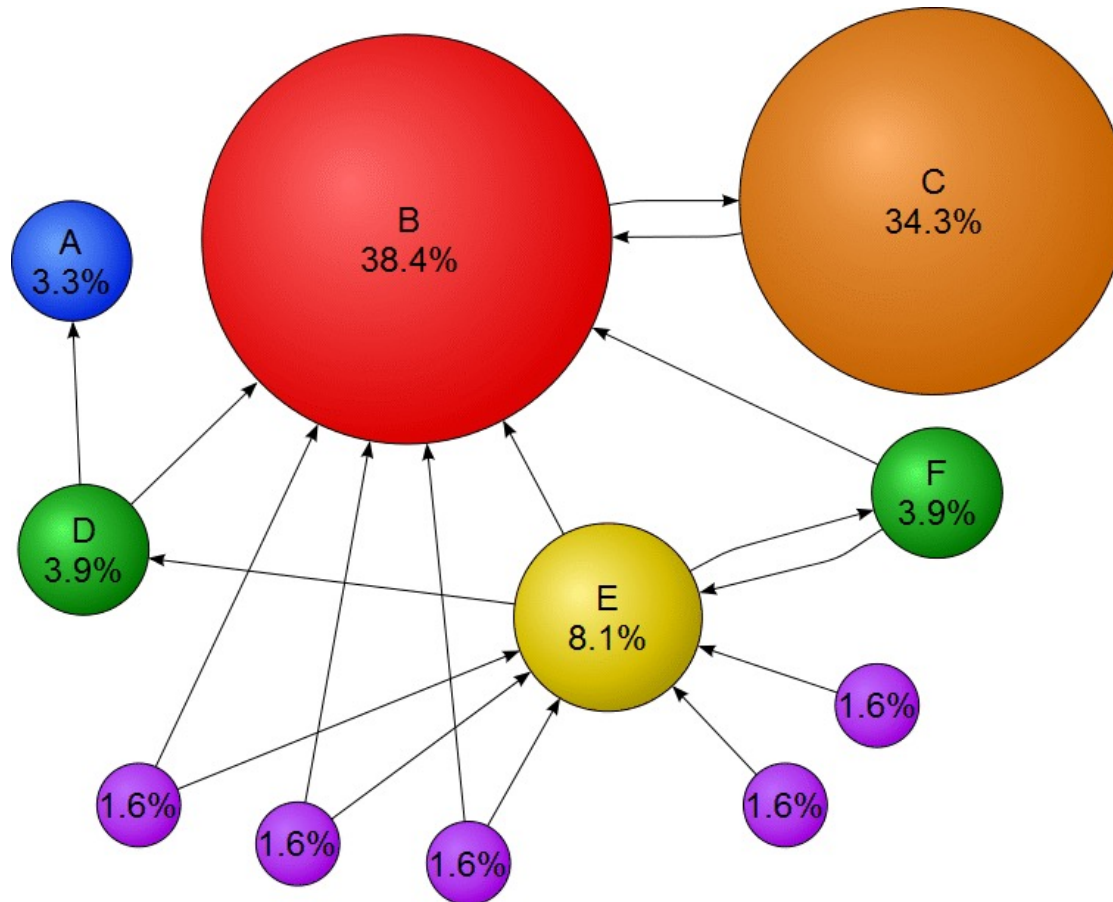

$$\text{PR}[v] = \frac{1 - \gamma}{|V|} + \gamma \sum_{u \in N^{-}(v)} \frac{\text{PR}[u]}{\text{deg}^{+}(u)}$$

# VertexMap

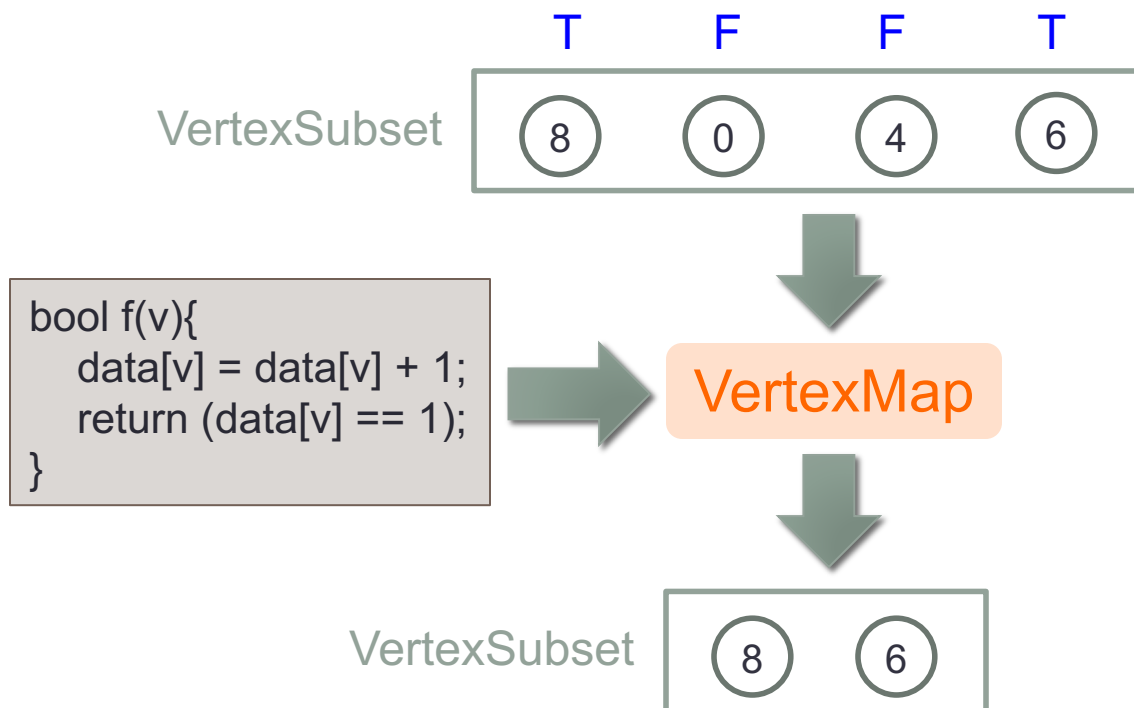
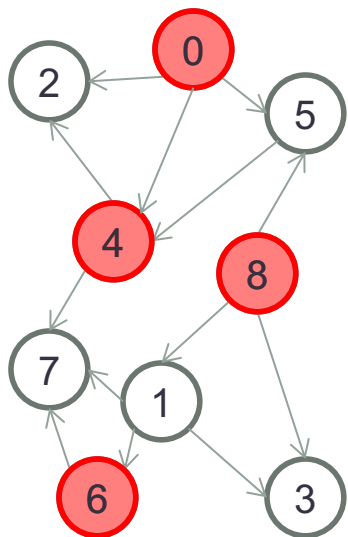

# PageRank in Ligra

```
p_curr = {1/|V|, ..., 1/|V|};    p_next = {0, ..., 0};    diff = {};    error = ∞;
```

```
procedure UPDATE(s, d):
```

```
    atomic_increment(p_next[d], p_curr[s] / degree(s));
```

```
    return 1;
```

```
procedure COMPUTE(i):
```

```
    p_next[i] =  $\alpha \cdot p\_next[i] + (1 - \alpha) \cdot (1/|V|)$ ;
```

```
    diff[i] = abs(p_next[i] - p_curr[i]);
```

```
    p_curr[i] = 0;
```

```
    return 1;
```

```
procedure PageRank(G,  $\alpha$ ,  $\epsilon$ ):
```

```
    frontier = {0, ..., |V|-1};
```

```
    while (error >  $\epsilon$ ):
```

```
        frontier = EDGEMAP(G, frontier, UPDATE, CONDtrue);
```

```
        frontier = VERTEXMAP(frontier, COMPUTE);
```

```
        error = sum of diff entries;
```

```
        swap(p_curr, p_next)
```

```
    return p_curr;
```

# PageRank

- *Sparse version?*
  - PageRank-Delta: Only update vertices whose PageRank value has changed by more than some  $\Delta$ -fraction (discussed in PowerGraph and McSherry WWW '05)



# PageRank-Delta in Ligra

```
PR[i] = {1/|V|, ..., 1/|V|};
nghSum = {0, ..., 0};
Change = {}; //store changes in PageRank values

procedure UPDATE(s, d): //passed to EdgeMap
    atomic_increment(nghSum[d], Change[s] / degree(s));
    return 1;

procedure COMPUTE(i): //passed to VertexMap
    Change[i] =  $\alpha \cdot$  nghSum[i];
    PR[i] = PR[i] + Change[i];
    return (abs(Change[i]) >  $\Delta$ ); //check if absolute value of change is big enough
```

# Performance of Ligra

# Ligra BFS Performance

Twitter graph (41M vertices, 1.5B edges)

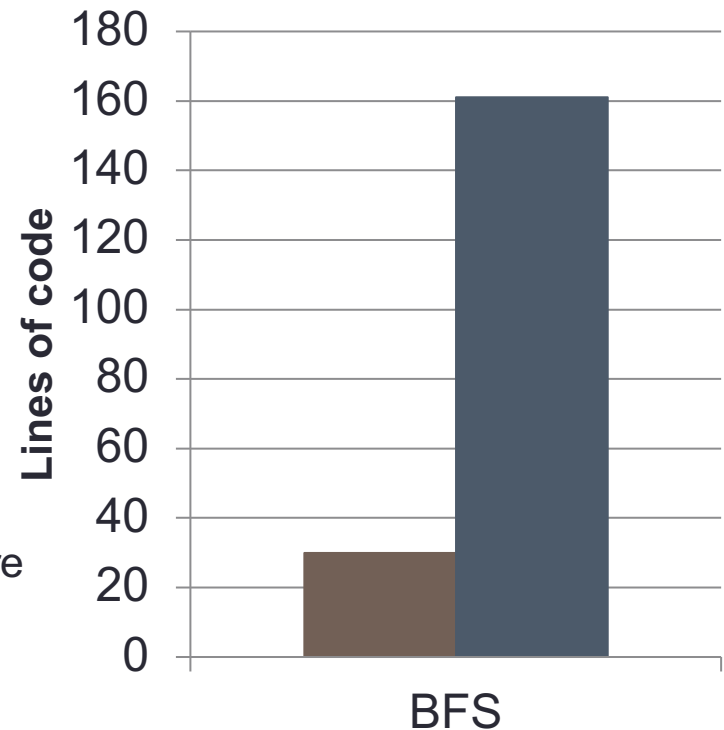
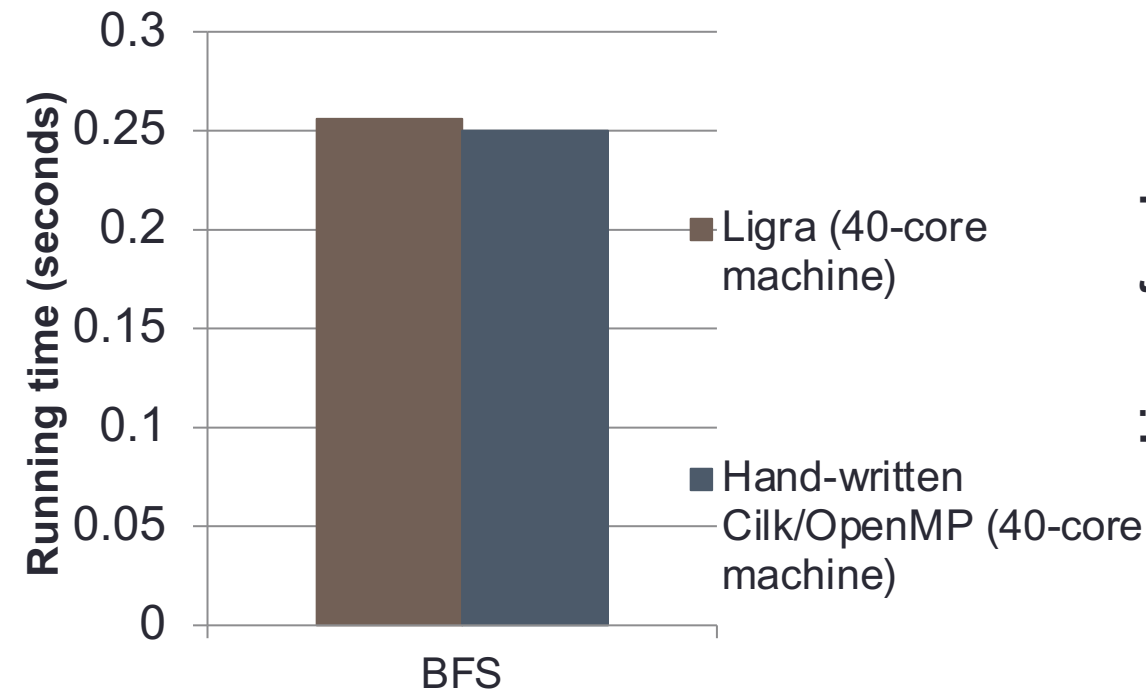

- Comparing against hybrid traversal BFS code by Beamer et al.

# Ligra PageRank Performance

Twitter graph (41M vertices, 1.5B edges)

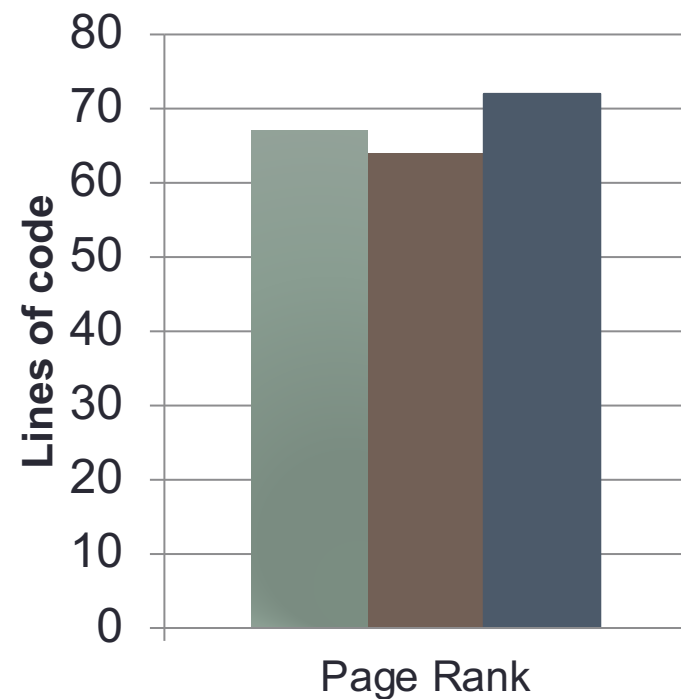
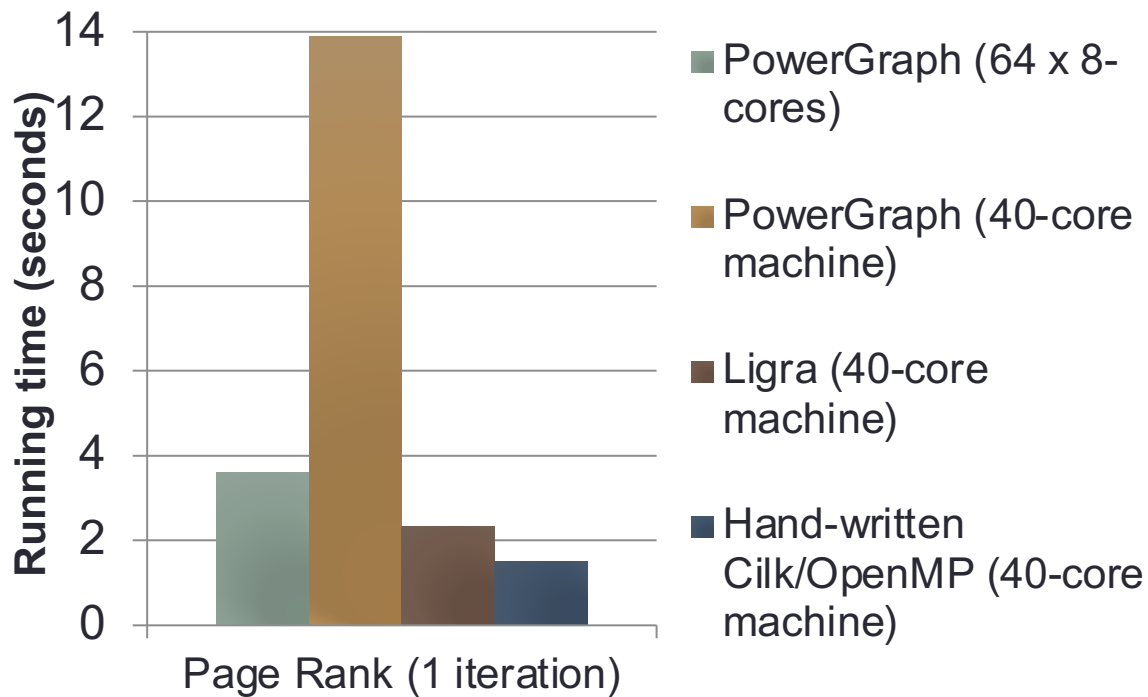

- Easy to implement “sparse” version of PageRank in Ligra

# Connected Components Performance

Twitter graph (41M vertices, 1.5B edges)

*Largest publicly available graph*

**Common Crawl**

3.5 billion vertices  
128 billion edges  
(540 GB)

Running time (seconds)

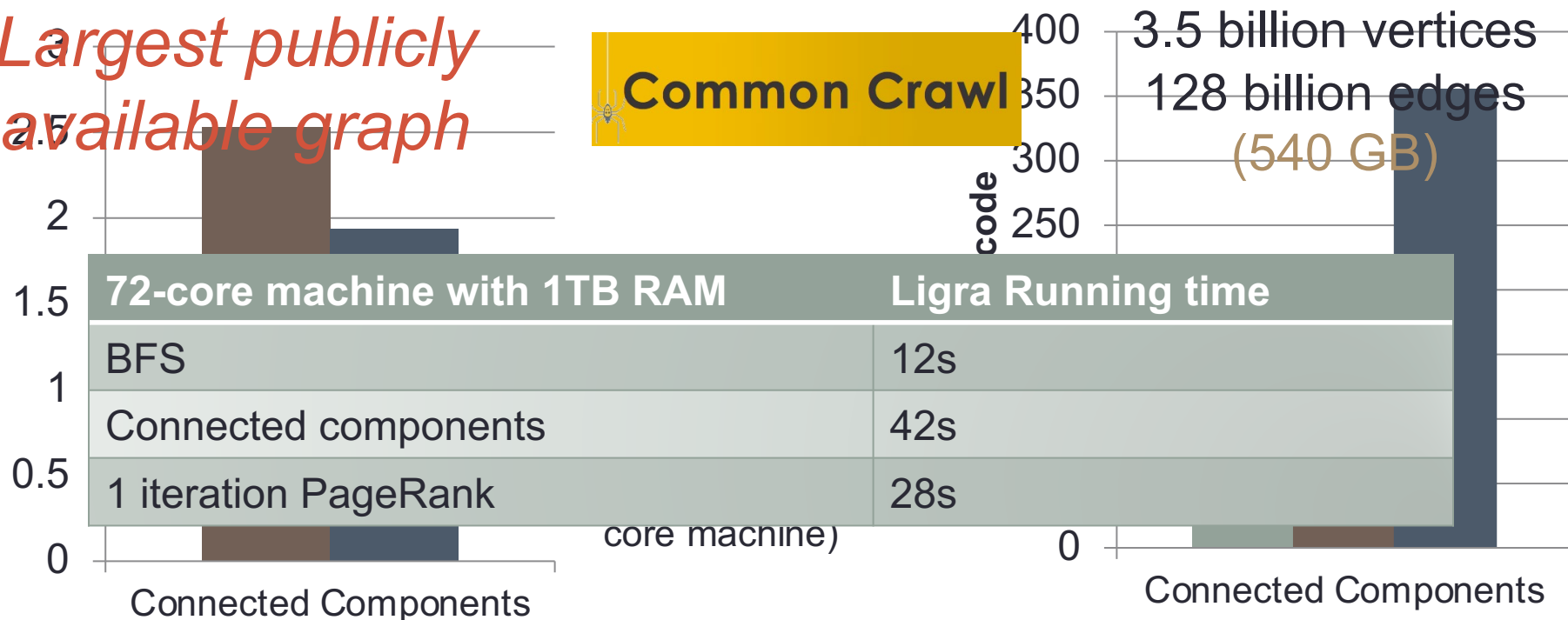

- Ligra's performance is close to hand-written code
- Faster than best existing system
- Subsequent systems have used Ligra's abstraction and hybrid traversal idea, e.g., Galois [SOSP '13], Polymer [PPoPP '15], Gunrock [PPoPP '16], Gemini [OSDI '16], GraphGrind [ICS '17], Grazelle [PPoPP '18]